



D40

Delivery Pallet Truck

ULTRA COMPACT DESIGN IS THE IDEAL SOLUTION FOR LIFT GATE AND LOCAL DELIVERY APPLICATIONS.

US Patents D739,112 : D770,719
D770,720: 9,586,605



"D40 shown with optional casters and with and without 48" load back rest, tool tray & load restraint.

CAPACITY

4000 lbs.

INTEGRAL BATTERY / CHARGER

(2) 12V 85AH maintenance free batteries
integral 110V smart charger.

TRAVEL SPEED

24-Volt ZAPI Travel Controller

Variable from 0 mph to 3.5 mph empty

Variable from 0 mph to 3.4 mph loaded

WEIGHT

650 lbs. with battery and charger

TIRES

DRIVE

9" x 3" polyurethane

LOAD

2.9" x 3.5" polyurethane

TILLER ARM CONTROLS

Travel, lift, and lower functions are located in the ergonomic operator handle. All operator controls are accessible without having to lift the hand from the handle.

Angle grips are designed to allow easy operation with either hand. Wrap around guard, reversing switch, thumb control, and horn are standard. Low mounted tiller arm offers excellent operator comfort and minimum steering effort. Gas assisted spring tiller handle gently returns to vertical position when released.

Crawl speed function with steer handle at 5° back-tilt from vertical allows for ease of use in tight areas.

ELECTRICAL

Electric braking, quick disconnect EPD power cut off, key switch and battery discharge indicator are standard equipment.

HYDRAULICS

Lift cylinder has hard chrome plated rods. Pump unit including motor, solenoid, gear pump, and pressure compensated lowering valve are mounted high in the power compartment for ease of service.

DRIVE UNIT

Vertically mounted AC drive motor is direct mounted to gear housing. Oil bathed bevel gear drive train with tapered roller bearings transfers power to axle.

State of the art optimized gear technology supplies advantages such as zero maintenance, low noise level, high efficiency and high performance.

Electromagnetic brake is mounted on motor armature shaft multiplying the braking power through the transmission. Brake is applied when control arm is in the vertical or horizontal handle position. System features anti-roll back and neutral braking.

ACCESSIBILITY

Water resistant removal three piece power head cover exposes major components and maintenance free AGM batteries for inspection and maintenance.

OPTIONAL EQUIPMENT

- Rubber Lug Drive Tire
- Stability Casters 3.3" x 1.9" polyurethane
- Poly Traction Tire
- 48" Tall Load Back Rest
- 60" Tall Load Back Rest
- Fork Width - 22" or 18"
- Fork Length - 36"
- Tool tray & Load Restraint
- Custom fork sizes available



BATTERY DISCHARGE INDICATOR, KEY SWITCH, EMERGENCY POWER DISCONNECT AND BUILT-IN AUTOMATIC BATTERY CHARGER

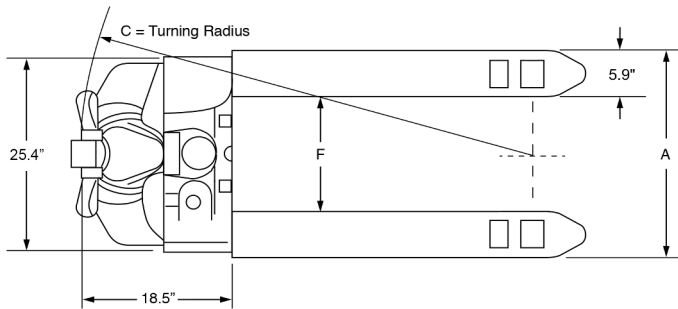
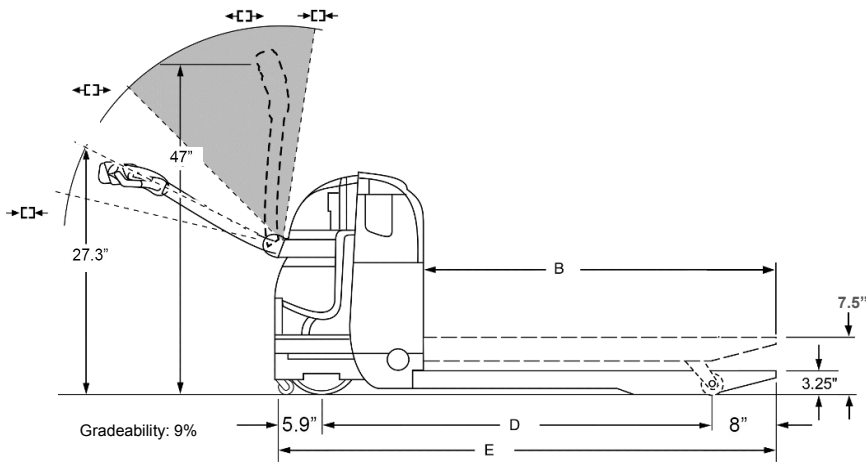

Truck Model	Forks	Actual Fork Width	Actual Fork Length	Turning Radius	Wheelbase	Overall Length	Inside Fork Width	Weight (lbs.)
		A	B	C	D	E	F	
Fork Dimensions: 27", 22", and 18" widths								
D 40	27 x 36	27	36	49	41.1	55	15.2	635
D 40	27 x 48	27	45.3	57.5	50.1	64	15.2	650
D 40	27 x 52	27	51	63.5	55.8	70	15.2	680
D 40	22 x 36	21.3	36	48.2	41.1	55	9.5	635
D 40	22 x 48	21.3	45.3	57.5	50.1	64	9.5	650
D 40	18 x 36	18	36	47.9	41.1	55	6.3	575
D 40	18 x 48	16.5	45.3	56.6	50.1	64	6.3	650

^aEstimated shipping weight with (2) battery

